

T-750 Jaw Crusher

Only from Red Knight 6 Ltd

01293 862619 - sales@redknight6.co.uk

The **T-750** combines superior crushing performance with the flexibility of a tracked undercarriage.

From unloading to operating in less than 10 minutes, the **T-750** jaw crusher harnesses the power of the on-board Diesel electric generator to crush 0-450mm rock, concrete and brick at typically 40-100tph.*

Boasting full electric controls, the unit can be tracked, set up and brought into full operation with the use of hydraulics and no complicated PLCs.

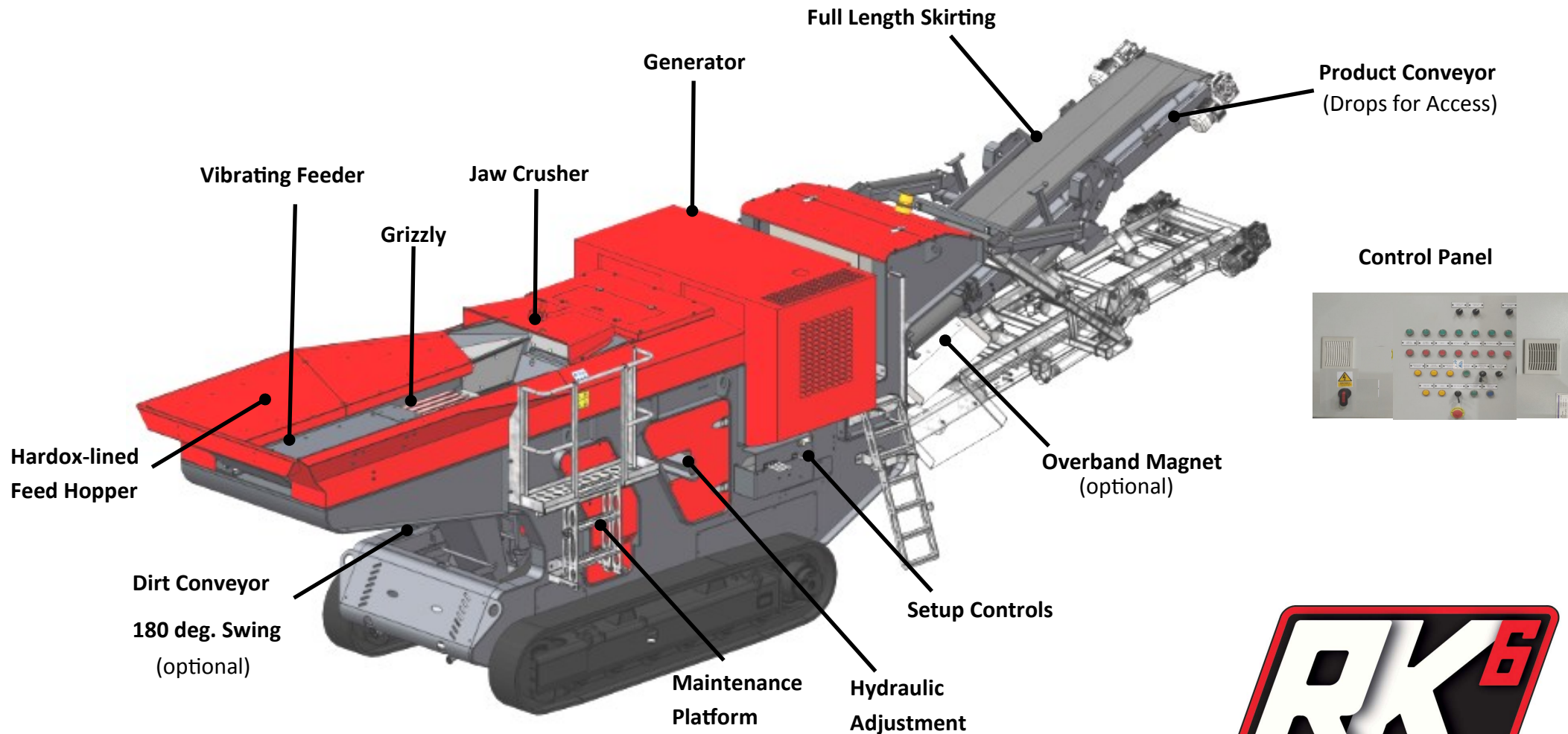

*Capacities achieved determined by feed material, method & desired product



T-750 Jaw Crusher

Only from Red Knight 6 Ltd

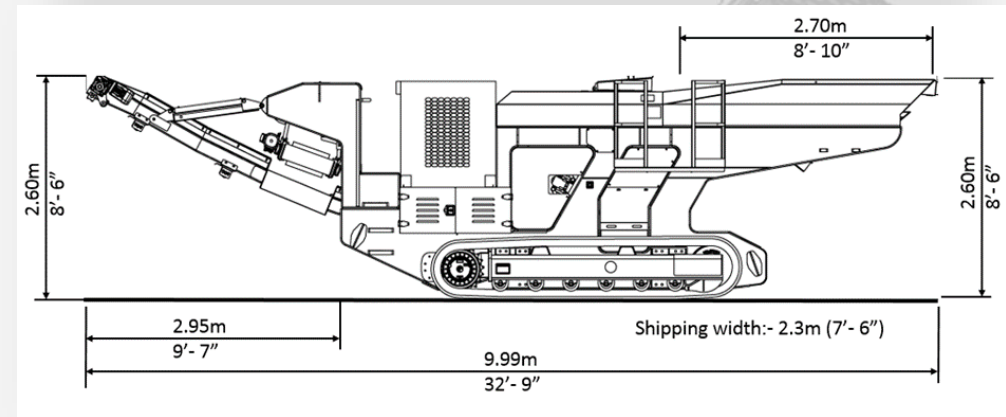

Specifications:-

Jaw Crusher	700x500 single toggle (45kW drive)
	6,000kg.s
Feeder	Fixed Hopper & Vibrating Grizzly
Conveyor	Hydraulic fold for transport
Chassis	Web & flange to suit tracks
Power Unit	Diesel electric generator (88kva) & dual power Full operation & service access
Operation	Overall:- 9.99m x 2.3m x 2.6m
	Feed height:- 2.6m (2.85m with risers)
	Stockpile height:- 2.6m (2.85m with risers) 9.9m x 2.3m x 2.6m (2.85m Ro-Ro)
Transport	19000kg.s
	12m High Cube shipping container / Ro-Ro
Options	Overband magnet Dust suppression
	Side belt Working lights
	Deflector plate Extended product conveyor



*Capacities achieved determined by feed material, method & desired product