



KOMPATTO 104

**TECHNICAL DATA
SPÉCIFICATIONS-PRODUIT
ESPECIFICACION TÉCNICA**

El KOMPATTO 104 es un criba mòvil asequible dirigida a operadores y contratistas pequeños y mediano que requieren un producto versàtil capaz de trabajar en una serie de aplicaciones como arena y grava, àrodos y reciclaje. Con su tiempo de preparaci3n ràpido, facilidad de operaci3n y característic3s como una caja de criba de dos pisos de alto rendimiento y dos cintas transportadoras hidràulicamente plegables de serie, esta es realmente una soluci3n excelente para una variedad de aplicaciones con capacidad de hasta 250tph.

Le KOMPATTO 104 est un cribleuse d'entr3e de gamme abordable, id3al pour les et moyens chantiers et soci3t3s qui ont besoin d'un produit polyvalent. Capable de fonctionner dans un certain nombre d'applications telles que le sable et les gravier, les granultas et le recyclage. Avec son temps d'installation rapide, sa facilit3 d'utilisation et ses fonctionnalit3s telles qu'un caisson de criblage à double 3tage à angle variable haute performance et trois convoyeurs de stockage hydrauliques pliants, c'est une excellente solution pour des besoins d'applications jusqu'à 25tph.



KOMPATTO 104

The KOMPATTO 104 is an affordable entry level screen ideally suited for small to medium sized operators and contractors who require a versatile product capable of operating in a number of applications such as sand and gravel, aggregates and recycling. With its rapid set up time, ease of operation and features such as A high performance double deck screen box and two hydraulically folding stockpile conveyors as standard this really is an excellent solution for a variety of applications with capacity of up to 250tph.

1. SCREEN BOX/CRIBLE/CRIBLA
2. FEEDER/ALIMENTATEUR/ALIMENTADOR
3. FINE SIZE/TAPIS FINES/CINTA FINO
4. MID-SIZE/GRAIN MOYEN/CINTA MEDIO
5. OVERSIZE/TAPIS DES GROS/ CINTA DE COLA
6. POWER UNIT/MOTEUR/ACCIONAMIENTO
7. CONTROL/COMMANDE/CONTROL
8. TRACKS/CHENILLES/ORUGA





TECHNICAL DATA

SPÉCIFICATIONS PRODUIT

ESPECIFICACION TÉCNICA

SCREEN BOX
CRIBLE CAISSON
CRIBLA

3000X1200mm (10'X4')

OUTPUT
POTENTIAL UP TO
PRODUCTION/
RENDEMENT JUSQU'A'
PRODUCCIÓN
HASTA

250tph / 275 US tph

POWERUNIT
MOTEUR
ACCIONAMIENTO

Stage V: 35kW / 45Hp Diesel Engine

Tier 4Final: 35kW / 45Hp Diesel Engine

Stage 3A: 36kW / 47Hp Diesel Engine

A Komplet Kompatto 104 excavator is shown in a construction site, equipped with a laser leveling system. The machine is positioned on a pile of dark soil and rocks. Several bright green laser lines are projected from the machine, creating a grid pattern on the ground to indicate a level surface. The background shows a hilly, excavated area under a clear sky.

WEIGHT
POIDS
PESO

7.000kgs (15.432lbs)

STANDARD MACHINE

GENERAL MACHINE

STANDARD

Remote control

Radio control

Remoto

OPTION

Punch plate – Mesh – Mesh Arpa

Plaque perforée – Mailles – Grille Losange

Planchas perforadas – Mallas – Mallas Arpa



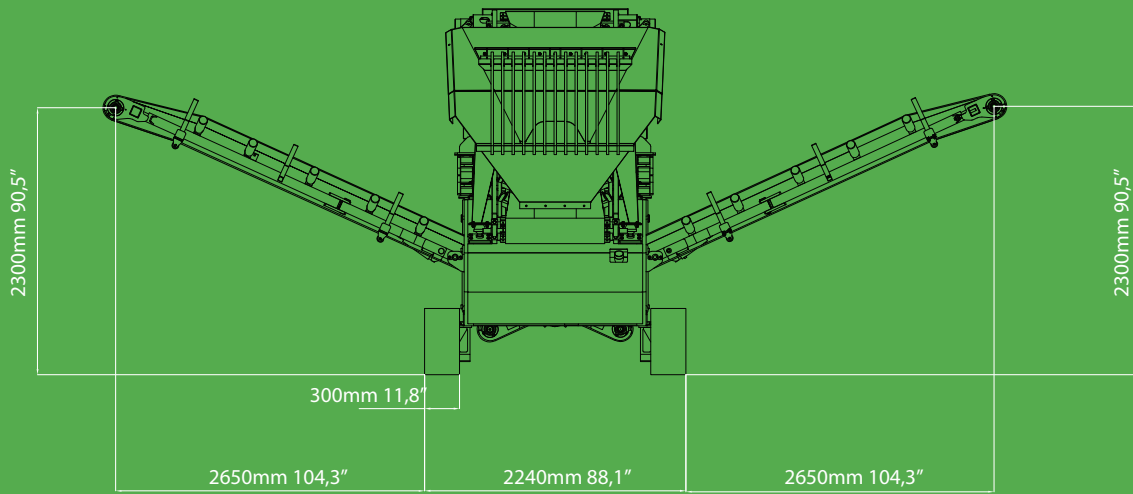
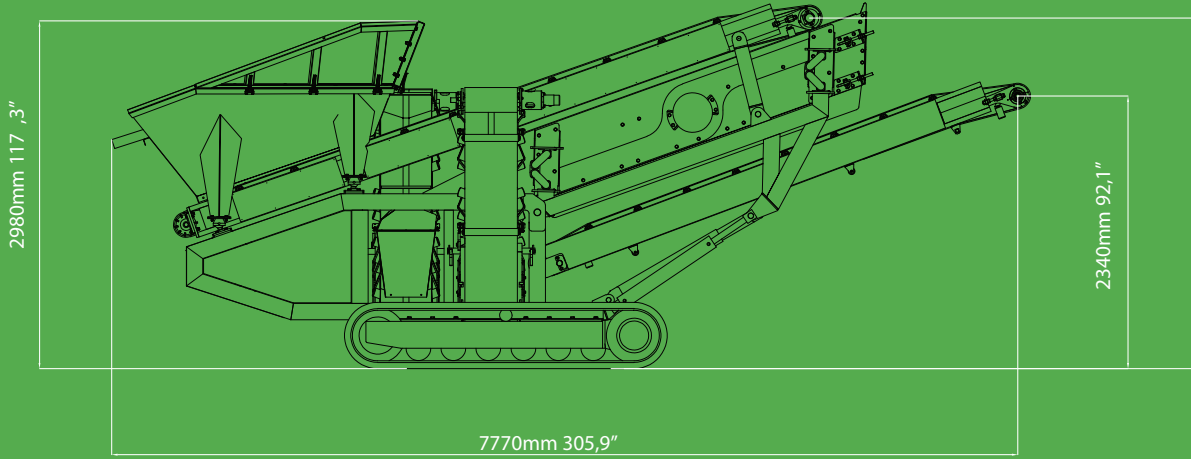

QUICK, EASY AND SAFE TRANSPORT
TRANSPORT RAPIDE, FACILE ET SÛR
TRANSPORTE RÀPIDO, FACIL Y ASEGURADO



DEALER

WWW.KOMPLET.IT
WWW.KOMPLETAMERICA.COM

